

# 36-CRRH

## Heavy Duty Chain Driven Live Roller with Hex Shaft (Roll-to-Roll Type)

The Model 36-CRRH is a heavy-duty, chain driven roller conveyor. Its tough, rugged design allows it to provide service under demanding manufacturing operations. Use the 36-CRRH for conveying heavy pallets and drums.

- 12 Bed Widths
- Center Drive
- Energy Efficient Motor - AC Variable Speed Controller
- Reversible
- Chain Driven Rollers
- Fixed HSF-Type Floor Supports Available



Conveyor shown with optional floor supports

HYTROL CONVEYOR COMPANY, INC.

SIZE TO ORDER Overall Length "A"	Conveying Surface	19 3/4"	21 3/4"	23 3/4"	27 3/4"	29 3/4"	33 3/4"	35 3/4"	41 3/4"	47 3/4"	53 3/4"	55 3/4"	63 3/4"
	Between Rail Width	23"	25"	27"	31"	33"	37"	39"	45"	51"	57"	59"	67"
	Overall Frame Width	26 27/32"	28 27/32"	30 27/32"	34 27/32"	36 27/32"	40 27/32"	42 27/32"	48 27/32"	54 27/32"	60 27/32"	62 27/32"	70 27/32"
10'	6" R/C	1284	1336	1387	1490	1541	1644	1695	1849	2003	2157	2208	2412
Per Foot		99	103	107	115	119	127	131	143	155	167	186	206
10'	12" R/C	1044	1076	1108	1172	1204	1268	1300	1396	1492	1588	1620	1748
Per Foot		75	78	81	87	90	96	99	108	117	126	129	141

All weights in catalog are conveyor weights only. Accessories, crating, etc., are not included.

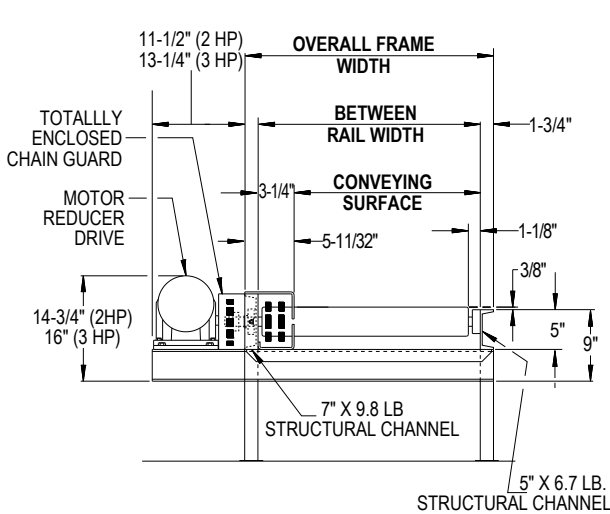
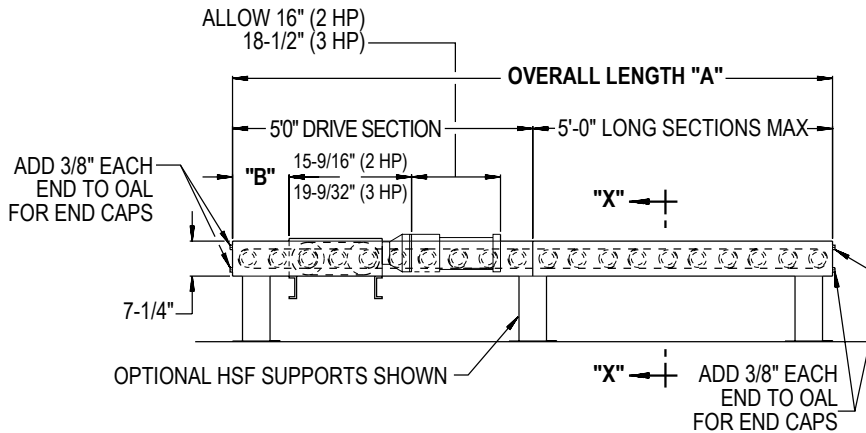

Roller Centers	"B"
6"	22 3/4"
12"	25 3/4"

SECTION X-X



## • STANDARD SPECIFICATIONS

**BED**—Roller bed with 3 1/2 in. x .300 in. wall unplated tread rollers with 1 1/8 in. hex shaft spaced every 6 in. or 12 in. Mounted in 5 ft. long powder painted structural steel channel frame bolted together with butt couplings.

**CENTER DRIVE**—Top side mounted drive, mounted to 5 ft. long section near center of conveyor. Chain guard located on left hand side.

**DRIVE CHAIN**—No. 60 roller chain.

**CHAIN GUARD**—Formed steel upper & lower chain guard mounted to top and bottom of channel frame to totally enclose drive chains.

**BEARINGS**—Sealed, pre-lubricated ball bearings.

**SPEED REDUCTION**—Heavy-duty sealed worm gear C-Face speed reducer. No. 80 roller chain to drive shaft.

**MOTOR**—2 HP—230/460V—3 Ph. 60 Hz. Energy Efficient C-Face motor and AC Variable Speed controller with softstart capability.

**CONVEYING SPEED**—Variable 3-30 FPM.

**CAPACITY**—Maximum load per linear foot of conveyor 2000 lbs. with supports on 5 ft. centers. NOT TO EXCEED CAPACITY IN CHART.

**FLOOR SUPPORTS**—Now supplied as optional equipment.

LOAD CAPACITY CHART @ 30 FPM									
HP	OVERALL FRAME WIDTH			OVERALL FRAME WIDTH			OVERALL FRAME WIDTH		
	26 27/32" to 30 27/32"			34 27/32" to 42 27/32"			48 27/32" to 62 27/32"		
	TOTAL LOAD (Lbs.)			TOTAL LOAD (Lbs.)			TOTAL LOAD (Lbs.)		
	UP TO 30'	UP TO 60'	UP TO 90'	UP TO 30'	UP TO 60'	UP TO 90'	UP TO 30'	UP TO 60'	UP TO 90'
2	21000	19200	17400	20400	18000	15600	19400	16000	12500
3	27000	25200	23400	26400	24000	21600	25400	22000	18500

**Note:** Capacities based on Hytrol supplied chain.

## • OPTIONAL EQUIPMENT

**FLOOR SUPPORTS**—HSF Type floor supports are available with a wide range of adjustment. Specify top of belt or roller elevation. One support required at every bed joint and ends of conveyor. Holes in feet for lagging to floor. Knee braces recommended above HSF-6 support.

**CONVEYING SPEED**—Other constant and variable speeds.

**NOTE:** Capacity affected with speed change. Contact factory.

**MOTORS**—3 HP maximum.

**ELECTRICAL CONTROLS**—Push-button stations.